

XT850

8" COAXIAL OUTDOOR SPEAKER

SOUNDTUBE
ENTERTAINMENT



Specifications: XT850

Mounting hardware included

Nominal Impedance	4 Ohms
Impedance (min)	3.7 ohm
Sensitivity dB @ 2.83V/1M	88.0 dB
Sensitivity dB @ 1W/1M (2)	85.0 dB
Frequency Response (± 3 dB)	51 Hz - 10 kHz
Frequency Response (± 10 dB)	38 Hz - 22 kHz
Max. Program Power	200W
Max. Continuous Power RMS	100W
Max. Power SPL @ 1 M	105.0 dB
Tap Selector	5 position rotary switch with transformer bypass
70.7 Volt Transformer Taps	64W / 103.0 dB
100 Volt Transformer Taps (dB)	64W / 103.0 dB
25 Volt Transformer Taps (dB)	8W / 94.0 dB
Transformer Options	25 / 70.7 / 100 Volt option with a 4 Ohm direct
Transducer - Low Frequency Driver	8" Polypropylene Cone w/ Butyl Rubber Surround
Transducer - High Frequency Driver	1" Convex Aluminum Tweeter
Network Type: Low Pass	6dB per octave, 1st order
Network Type: High Pass	6dB per octave, 1st order
Coverage Angle (-6 dB @ 10 kHz)	360 horizontal 40 vertical
Coverage Angle (-6 dB @ 2 kHz)	360 horizontal 40 vertical
Colors	Granite green or sandstone
Connections	18-Gauge wire lead
Height (SM = Height)	417.1 mm / 16.42 in
Diameter (SM = Width)	359.9 mm / 14.17 in
Weight	7.6 kG / 16.7 lbs
Shipping Weight	10 kG / 22 lbs
Packaging	1 per box
Regulatory - UL	Approved UL1480A
Regulatory - CE	approved
Regulatory - IP	ip55_approved

Key Features

- Patented BroadBeam® waveguide technology provides smooth 360° horizontal off-axis coverage and reduces overall system costs.
- One 8.0 in (203 mm) weatherproof polypropylene woofer with butyl rubber surround and one 1.0 in (25 mm) aluminum dome tweeter with integrated horn & mounting bracket.
- UV-, scratch-, chlorine-, and weather-resistant with professional-grade components for long-lasting performance and durability.
- Patented, durable and weather sealed Zero-Reflection™ enclosure.
- Weather-proof 5-position tap switch for 25/70.7/100 Volt applications with transformer bypass position. 64 Watt transformer included.
- Liquid-tight compression fittings for water-tight protection.
- Multiple wire inlet locations for fast and easy daisy chaining.
- Stainless steel fasteners & grille.
- UL 1480 (UEAY) pending.
- Color options: granite green or sandstone

Description

The SoundTube XT850 is a premium 2-way outdoor loudspeaker solution for installations requiring high-performance sound in a durable speaker design. The XT850 is designed for full-range background/foreground music and paging. The sealed, in-ground enclosure design delivers true low end response (38 Hz, -10 dB) and optimal off axis performance. The XT850 includes theft-resistant mounting hardware and a weather-proof 5-position tap switch for 25/70.7/100 Volt applications with transformer bypass position.

Applications

The ultra-wide 360° horizontal dispersion pattern makes the XT850 an ideal choice for theme parks, promenades, playgrounds, shopping malls, restaurants, resorts, gardens and other outdoor applications. XT850 speakers come with in-ground anti-theft brackets and stainless-steel square-tip screws for increased outdoor security.

Patented SoundTube Technologies

SoundTube and MSE Audio Group constantly develop new technologies that enhance audio product performance. SoundTube innovations are protected by multiple U.S. and international patents, which explicitly cover SoundTube dispersion, enclosure and dome technologies. MSE Audio Group actively defends its patents in order to protect SoundTube resellers and end users.

Technical Data and Specification Tools

Technical Data

SoundTube Entertainment strives to provide complete and effective technical information and data to dealers, engineers and designers. All data are available from SoundTube Entertainment or at www.soundtube.com. Technical data and downloads include: EASE™ data - 3-D polar plots. EASE™ Address - 2-D modeling for distributed systems Autodesk® Revit® software Tech Sheets - Technical information and architectural specs for system engineers SoundTubeSPEC™ - Proprietary speaker placement software

Data Acquisition and Verification

All data for SoundTube speakers are independently collected from and verified by NWAALabs (www.nwaalabs.com) using their proprietary MACH testing system. All data are collected and analyzed according to ASTM, ISO and AES standards using EASRA, TEF and MLSSA. Full balloon data including both phase and magnitude are compiled into a variety of formats including EASE 4.x, GLL and CLF.

Architectural Specifications

The loudspeaker shall be of in-ground design consisting of one 203 mm (8.0 in) low frequency transducer and one 25 mm (1.0 in) aluminum dome high-frequency transducer with a frequency-dividing network installed in a sealed enclosure. The low-frequency voice coil diameter shall be 32 mm (1.26 in). Performance specifications of a typical production unit shall be as follows: Usable frequency response shall extend from 38 Hz - 22 kHz (-10 dB). Measured sensitivity (2.83 Volt input, 1 meter) shall be at least 88 dB. The maximum continuous output at 1 meter shall be 105.0 dB. Rated power capacity of the components and network shall be at least 100 Watts continuous RMS power. The loudspeaker shall have a nominal impedance of 4 Ohms and be available for 25/70.7/100 Volt modes with transformer bypass position. The frequency-dividing network shall have a crossover frequency of 3.0 kHz. The enclosure shall be constructed of a roto-molded polyethylene plastic. The grille shall be constructed of powder coated stainless steel. Color options shall be granite green or sandstone. All transducers and network circuitry are weather resistant and housed in a sealed enclosure. Installation shall be by in-ground mount. The external wiring input connector shall be hard wire leads. The overall cabinet dimensions shall be no more than 360 mm (14.17 in) in diameter by 417 mm (16.42 in) in height and shall weigh no more than 7.5 kg (16.7 lbs). The low-frequency transducer shall have a

weatherproof butyl rubber surround to resist weather, elements and insects. The high frequency transducer shall be a horn-loaded dome and constructed of aluminum. For theft deterrence, all units come with anti theft brackets and square-tip screws. The system shall be the XT850 for both low and high impedance applications.

SoundTube

8005 W. 110th St. | Suite 208
Overland Park, KS 66210
Phone 9136635600
Fax 8556635600
Toll Free 8556635600
<http://soundtube.mseaudio.com>
All SoundTube products come with a 5-year limited warranty.

XT850

8" COAXIAL OUTDOOR SPEAKER

SOUNDTUBE
ENTERTAINMENT

Graphs and Plots

Frequency Response

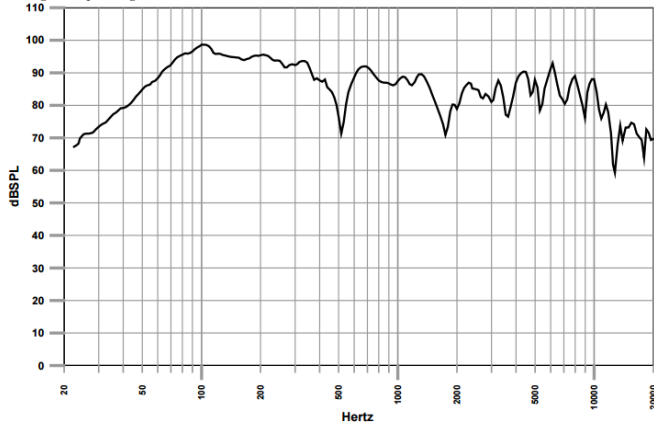

Phase/Impedance Response

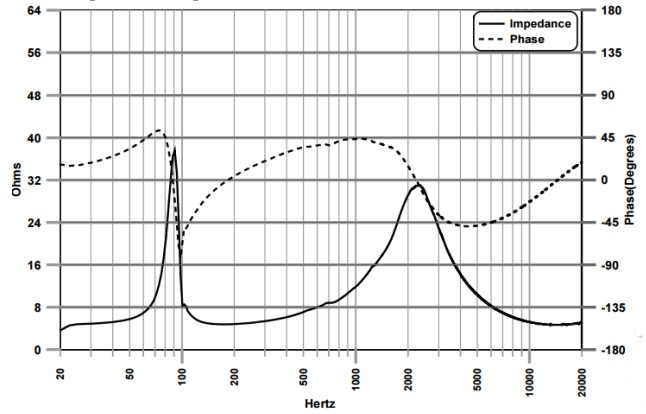

XT850

8" COAXIAL OUTDOOR SPEAKER

SOUNDTUBE
ENTERTAINMENT

Mechanical Drawings

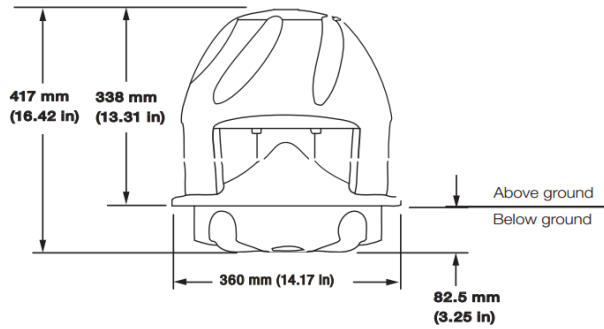

Included Accessories



Anti-theft hardware