

# SD-250

## SD-250 Amplifier

SOUNDTUBE  
ENTERTAINMENT



### Specifications: SD-250

### Mounting hardware included

Input Impedance	47 kohm
Max Gain	34 dB (8 ohm)
Bridged Mono Power @ < 1 % THD	90 watts (4 ohms)
Signal to Noise Ratio	> 83 dB (50 watts)
Height (SM = Height)	31.2 mm / 1.23 in
Diameter (SM = Width)	101.1 mm / 3.98 in
SM Depth (Including Bracket)	123.6 mm / 4.86 in
Depth	123.6 mm / 4.86 in
Weight	.26 kg / .56 lbs
Accessories Optional	Rack Mount Adapter (AC-SD-250-RMA)
Packaging	One per box
Regulatory - CE	approved
Regulatory - RoHS	approved

### Description

34 dB maximum gain with 2 x 50 watt output. Three operating modes: stereo, mono or bridged mono. Three SolidDrive EQ settings for drywall, wood and glass, plus a full-range flat option (no EQ). Three user selectable inputs: balanced stereo euroblock, stereo unbalanced mini jack, or high level euroblock.

External 12-32 V trigger. Signal detecting auto standby to conserve energy. Dual concentric gain controls for independent channel control. 20 Hz- 20 kHz frequency response. Rugged aluminum housing.

### Applications

Small, powerful and cost-effective, the SD-250 is engineered for external amplification with SolidDrive and other high-fidelity speakers. Additional applications include digital signage, education, point of purchase, museums, surgical centers, AV carts or any application where a small amplifier is needed to boost a limited source output (e.g., computers, A/V projectors, etc.).

### Patented SoundTube Technologies

SoundTube and MSE Audio Group constantly develop new technologies that enhance audio product performance. SoundTube innovations are protected by multiple U.S. and international patents, which explicitly cover SoundTube dispersion, enclosure and dome technologies. MSE Audio Group actively defends its patents in order to protect SoundTube resellers and end users.

### Technical Data and Specification Tools

#### Technical Data

SoundTube Entertainment strives to provide complete and effective technical information and data to dealers, engineers and designers. All data are available from SoundTube Entertainment or at [www.soundtube.com](http://www.soundtube.com). Technical data and downloads include: EASE™ data - 3-D polar plots. EASE™ Address - 2-D modeling for distributed systems Autodesk® Revit® software Tech Sheets -

Technical information and architectural specs for system engineers  
SoundTubeSPEC™ - Proprietary speaker placement software

### Data Acquisition and Verification

All data for SoundTube speakers are independently collected from and verified by NWAALabs ([www.nwaalabs.com](http://www.nwaalabs.com)) using their proprietary MACH testing system. All data are collected and analyzed according to ASTM, ISO and AES standards using EASRA, TEF and MLSSA. Full balloon data including both phase and magnitude are compiled into a variety of formats including EASE 4.x, GLL and CLF.

### Preliminary Technical Information

- 34 dB maximum gain with 2 x 50 watt output.
- Three operating modes: stereo, mono or bridged mono
- Three SolidDrive EQ settings for drywall, wood and glass, plus a full-range flat option (no EQ).
- Three user selectable inputs: balanced stereo euroblock, stereo unbalanced mini jack, or high level euroblock.
- External 12-32 V trigger

- Signal detecting auto standby to conserve energy
- Dual concentric gain controls for independent channel control
- 20 Hz- 20 kHz frequency response
- Small size- 1.2" x 3.9" x 4"
- Rugged aluminum housing
- Optional Accessories: rack mount adapter kit (AC-SD-250-RMA)

## Architectural Specifications

The amplifier shall be a 50-watt per channel (8 ohm) Class D amplifier. The amplifier shall provide three inputs including a balanced stereo euroblock, unbalanced line level mini jack, and a stereo speaker level (amplified) euroblock input for applications with low wattage speaker outputs. The SD-250 also includes a variable 34 dB maximum gain control. The amplifier shall provide three operating modes including stereo, dual mono, or bridged mono. Performance specifications of a typical production unit shall be as follows: 50 watts per channel (20 Hz - 20 kHz, 8 ohm, stereo) or 65 watts per channel (20 Hz - 20 kHz, 4 ohm stereo) at >1% THD. Three preset EQ settings allow the SD-250 to work

with an SD1 speaker in drywall, glass and wood applications. The SD-250 also has a full-range option with no EQ setting. The external wiring output connector shall be a Euroblock connector that accepts from 10 - 22-gauge wire. The power input shall either be by three pin Euroblock that accepts from 10 - 22-gauge wire or barrel connection. The system shall be for indoor applications. The enclosure shall be constructed of extruded aluminum with integrated heat-sink. Overall chassis dimensions shall be no more than 30.5 mm (1.2 in.) in height by 99.1 mm (3.9 in.) in width and 101.6 mm (4.0 in.) in depth. The system shall include the amplifier, pole/surface mount adapter, power supply, stereo RCA female to mini male adapter, two male 4-pin euroblock connectors and two 3-pin euroblock connectors. The system shall be the SD-250 for amplification.

### SoundTube

8005 W. 110th St. | Suite 208  
Overland Park, KS 66210  
Phone 9136635600  
Fax 8556635600  
Toll Free 8556635600  
<https://soundtube.mseaudio.com>  
All SoundTube products come with a 5-year limited warranty.

# SD-250

SD-250 Amplifier

SOUNDTUBE  
ENTERTAINMENT

## Mechanical Drawings

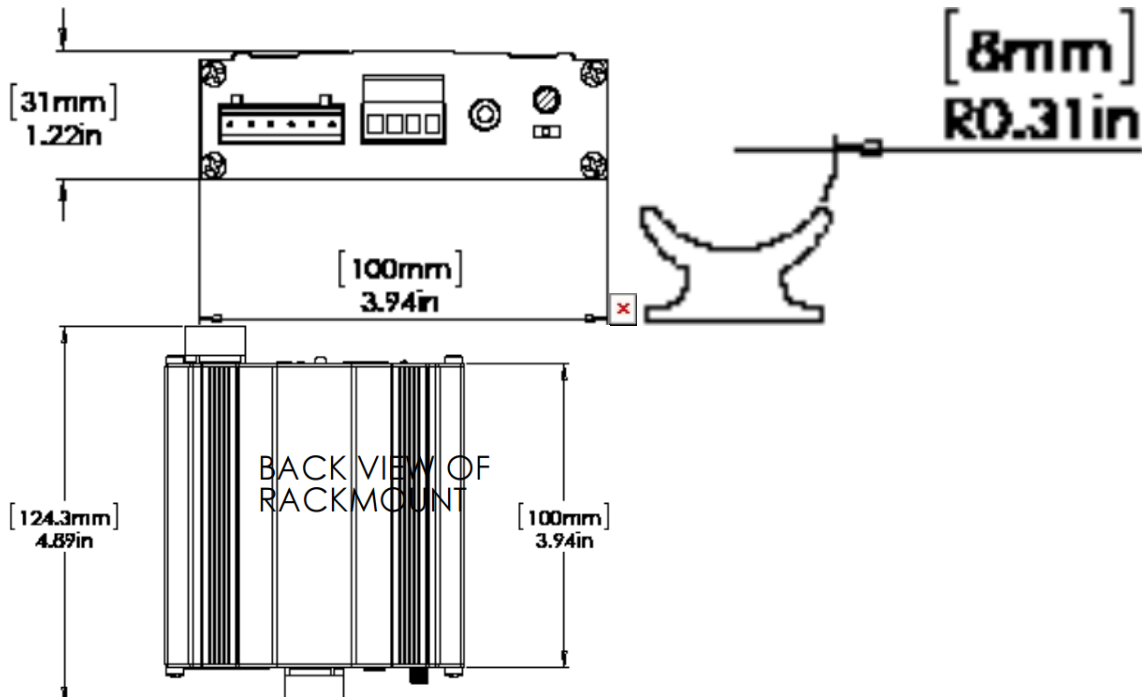

## Optional Accessories



**Rack Mount Adapter (AC-SD-250-RMA)**